

SHOWER & TUB/SHOWER INSTALLATION

Clarion
EVERYDAY LUXURY

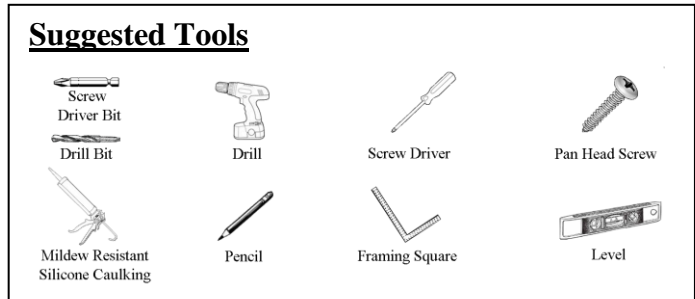

Please consult all local and state building codes and read the entire installation instructions prior to beginning the installation of this unit to ensure that the installation is performed correctly.

Clarion Bathware's tub/showers are to be stored in a dry area prior to installation to prevent moisture from attacking the reinforcement material which could cause warpage to the unit.

WARNING: FAILURE TO FOLLOW THESE INSTALLATION INSTRUCTIONS COULD VOID THIS PRODUCTS WARRANTY. A licensed plumber is required to install or supervise the installation of these units. These units are thoroughly tested in the plant to ensure their ability to drain water properly. Failure to follow these handling and installation instructions may cause improper drainage, thus voiding the unit's warranty.

Pocket dimensions and drain location can be obtained from your retailer or at www.clarionbathware.com/search (1) enter model number of the unit then click search, (2) select the product picture, (3) under downloads and maintenance select the product cut sheet (pdf).

Note: No foundation materials are required on Clarion Bathware Showers and Tub/showers. Clarion Bathware's products are designed to be self-supporting. However, in cases where the occupant of the home has excessive weight, we recommend that the unit be installed on a bedding material of cement or casting plaster.

Step #1

Figure 1 Framing the Pocket

Frame a square and plumb pocket to dimension of the unit. If the unit being installed has a whirlpool option installed, future access to the pump and parts should be considered when installing. It is advised, and is required by many local and state building codes that an access area be incorporated into the framing for a whirlpooled tub/shower

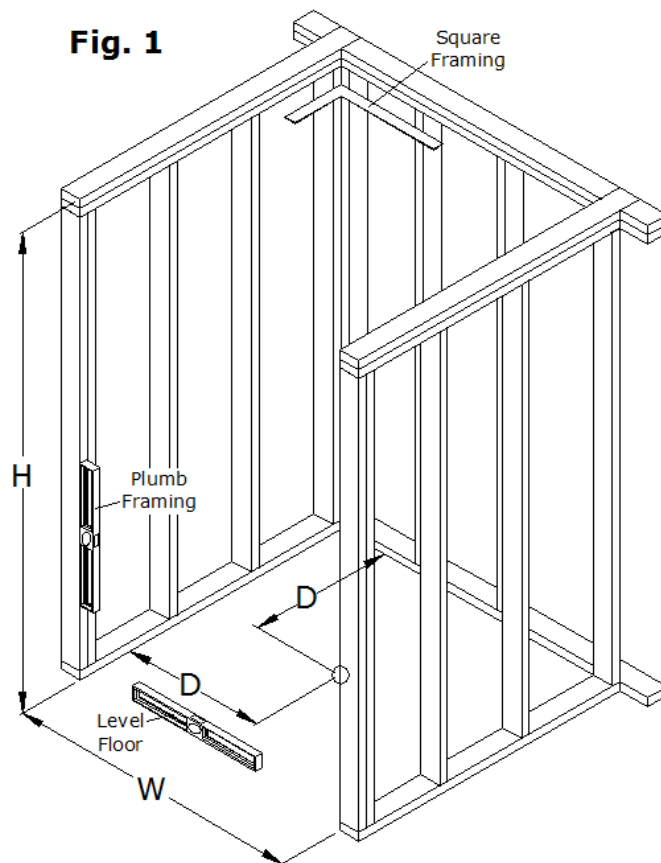

* H= Height of framing pocket should be at least the height of unit that is being installed.

* W= Width of framing pocket should be no wider than the width of the unit being installed. Shims may be required.

* D= Dimensions provided on the cutsheet of the unit which show the drain location.

NOTE: Accommodations should be made in the pocket dimensions for any accessories attached to the unit.

Step #2

Figure 2 Setting the Unit

Plumbing fixture can be installed prior to setting the unit into the framing pocket or after.

Install the drain and make sure that it is sealed properly and not leaking. Set the unit into the framed pocket. Check that the drain is not resting on anything which can force the unit floor upwards. Plumb and level the unit. The legs of the unit must contact the floor for proper support. Shims may be placed under the legs to maintain solid contact where needed.

Use appropriate size shims to fill any gaps between the flange and the framing members. Once the unit is plumb and level and any gaps are shimmed, secure the vertical flanges every 6" or as necessary and the horizontal flanges wherever they come into contact with the studding with galvanized nails or screws. Pre-drilling for the fasteners may be desired to reduce the risk of damaging the unit.

Fig. 2

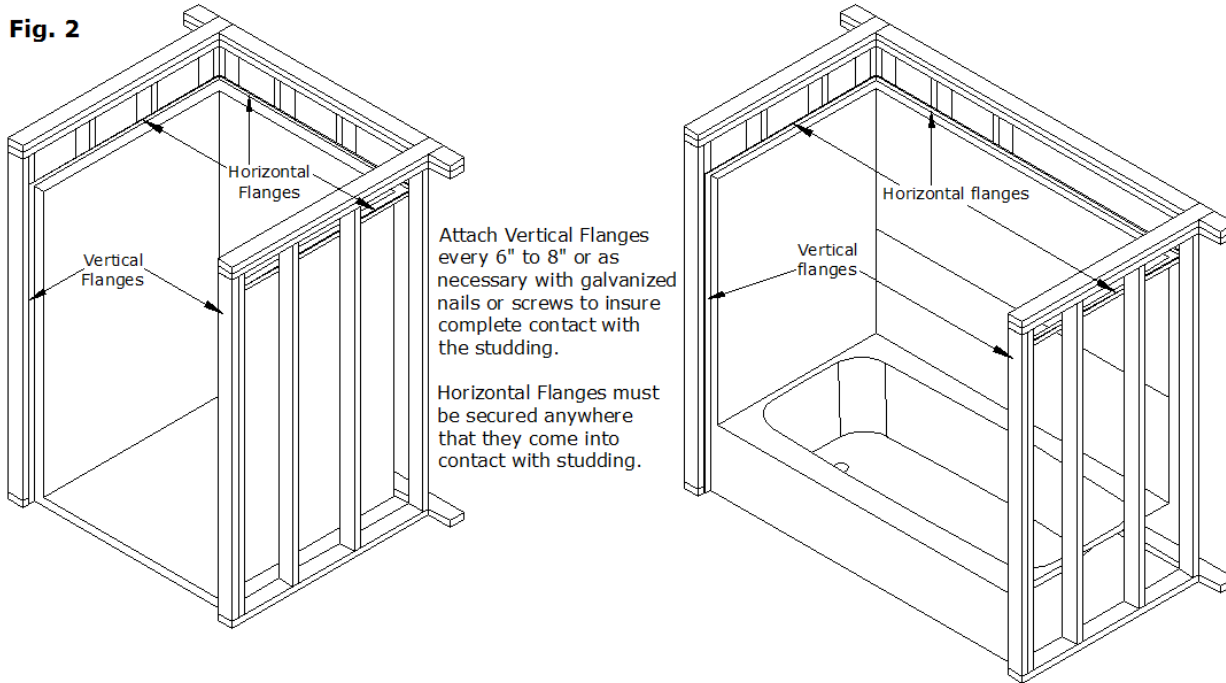

(In an application where the unit is installed over wall board, the Clarion Bathware E-Z Wall Trim Kit (Fig 3) will help you finish your installation quick and easy. For best results your fasteners will need to be flush with the nailing flange. Clarion Bathware recommends centering and counter sinking a corrosion resistance fastener on the nailing flange. Raised fasteners will result in a problematic finishing process of the trim kit.)

E-Z Wall Trim (Fig 3): Clarion Bathware's offers E-Z Wall Trim for a quick and easy installation to finish off the wall nailing flange when the unit is installed over wall board. E-Z Wall Trim is available in pieces or in pre-mitered kits. Contact your supplier or call (800) 576-9228 for more details.

E-Z Wall Trim Application

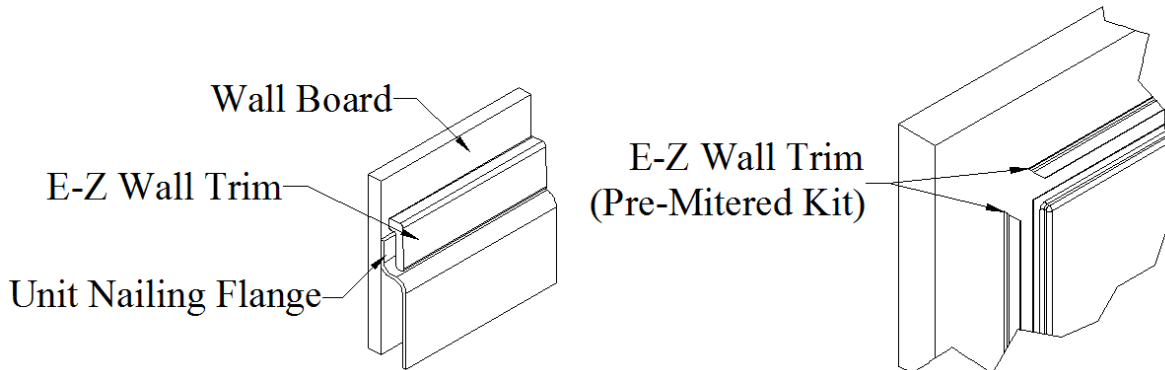

Fig 3

Final Notes:

You can finish off your new unit with a variety of materials which are accepted by local building codes. Some ideas are tile, drywall caulking, drywall mud, plaster, wood or plastic trim.

Clean your new tub with a liquid detergent and warm water.
Do not use any abrasive cleaners such as scouring powder or liquid abrasive cleaners.

IF A BEDDING MATERIAL IS USED UNDER A UNIT; CEMENT SLURRY, THIN MORTAR MIX, PLASTER OF PARIS, OR A COMPARABLE FLOOR FILLING COMPOUND THAT IS NOT WATER SOLUBLE ARE PROPER BEDDING COMPOUNDS. WATER SOLUBLE MATERIALS, FOAM AND OTHER EXPANDING MATERIALS ARE NEVER TO BE USED AS A BEDDING COMPOUND.

NOTE: ANY BATHING WELL CAN BE WHIRLPOOLED. IT IS IMPORTANT TO DETERMINE WHERE YOU WILL HAVE ACCESS TO THE PUMP IF IT NEEDS SERVICED IN THE FUTURE. ACCESS TO THE WHIRLPOOL PUMP AND PARTS SHOULD BE CONSIDERED PRIOR TO PURCHASING AND/OR INSTALLING A WHIRLPOOLED UNIT. AN ACCESS AREA ON WHIRLPOOLS IS REQUIRED BY MANY BUILDING CODES. ALL WHIRLPOOLS MUST BE WATER TESTED PRIOR TO BEING INSTALLED. FAILURE TO WATER TEST CAN VOID THE WARRANTY.

IF YOU HAVE ANY QUESTIONS REGARDING INSTALLATION OF YOUR CLARION BATHWARE PRODUCT, PLEASE CALL OUR CUSTOMER SERVICE DEPARTMENT AT 1 (800) 576-9228 EXT. #818 OR BY E-MAIL AT CUSTOMERSERVICE@CLARIONBATHWARE.COM

JOB SITE INSTALLATION OF OWNER SUPPLIED ACCESSORIES

All Clarion Bathware units purchased with supplied grab bars are custom reinforced at the factory to accommodate the mounting of said bars.

Any grab bars installed on a Clarion Bathware unit at the job site must have proper reinforcement (wood support and backing plates) at all mounting areas and should comply with ANSI A117.1, Uniform Federal Accessibility Standards (UFAS) and ASTM F446 specifications for grab bars in the bathing area.

Job-site installation of third party supplied grab bars is entirely at the risk and full responsibility of the owner. Any damage to Clarion Bathware units or the property during or after grab bar installation, or any injuries due to improper installation remain the sole responsibility of said owner and cannot be attributed to Clarion Bathware, Inc.

*****WE SUGGEST THAT THE CUSTOMER AVOIDS USING A BATH MAT IN THE UNIT, AS IT COULD CAUSE WATER STAINS OR BLISTERING TO THE FINISH SURFACE OF THE UNIT.**

CLARION BATHWARE PRODUCTS ARE CERTIFIED TO MEET NAHB STANDARDS, HUD/FHA, BOCA, HUD UM-73A, ANSI Z124.1 AND ANSI Z124.2. FOR DETAILS, REQUEST NAHB RESEARCH CENTER CONFIRMATION.

EVERYDAY LUXURY

44 Amsler Avenue Shippenville, PA 16254
(814) 226-5374 (800) 576-9228
Customer Service: Ext. #818
Fax: (814) 226-0730
www.clarionbathware.com



AcrylX™ with the Strength of ArmorCore™ Lifetime Warranty



This warranty applies to all Clarion Bathware AcrylX™ with ArmorCore™ base reinforcement produced after 1-23-2017.

Clarion Bathware warrants to the original purchaser and consumer that its products will be free from defects in material or workmanship when properly installed pursuant to Clarion Bathware installation instructions for the following warranty periods:

Lifetime Warranty

- (1) AcrylX™, Residential* Use
- (2) CenturyStone™, Residential* Use

Thirty (30) Year Warranty

- (1) AcrylX™, Commercial* Use
- (2) CenturyStone™, Commercial* Use

All accessories or purchased parts carry a (1) year warranty.

Upon inspection by an authorized representative, Clarion Bathware will repair or exchange at its sole discretion, any unit found to be defective in material or workmanship. The exchange of a unit will only be considered when Clarion Bathware has eliminated all options to restore the unit to acceptable factory condition. Exchange of a unit is limited to supplying replacement product of comparable size and style, and does not include any cost of removal or installation.

EXCEPTIONS

This warranty shall be voided if the unit is moved from its place of initial installation or is not installed in accordance with the instructions supplied by the manufacturer of the unit. Clarion Bathware will not be held responsible for any damages resulting from improper installation.

Further, this warranty does not apply if the unit has been subjected to accident, abuse, misuse, damage caused by flood, fire, or other force of nature.

Any unauthorized repair or modification to the product would render the warranty null and void.

This warranty does not apply to any equipment or accessories not installed by Clarion Bathware and Clarion Bathware will not be held liable for any results of such acts.

Clarion Bathware is not responsible for any consequential or incidental mishaps, inconvenience, time loss, incidental expense, materials or labor related to the installation of hardware or the actual tub.

The owner agrees by use of the unit that the obligations of Clarion Bathware shall not extend to contingent or indirect damage or injury to the structure of its contents, that the obligations of Clarion Bathware are limited to those set forth herein, and that no other obligations, expressed or implied, are assumed by Clarion Bathware.

The product is not recommended for outside storage.

To obtain warranty service, the Customer must give prompt notice to Clarion Bathware of any claim.

Clarion Bathware is a division of American Bath Group Inc.

*Residential Use is considered any unit installed in a permanent residence dwelling of individual ownership, such as but not limited to single family home, multi-family home, or condominium. Commercial Use is considered transient lodging, such as but not limited to healthcare facility, dormitory, hotel, or apartment complex.